



## HYDROMINE™ HMP\_11A SANS 665 / BS 5163 PN16 Resilient Seal Gate Valves

### Overview:

The HYDROMINE™ HMP\_11A PN16 Resilient Seal Gate valve were designed for easy seating. Not a lot of force is needed for the closing of the valve, due to the EDPM (rubber) encapsulated gate. This valve is widely used in low pressure applications below 1.6 MPa such as water treatment, water distribution, mining and power generations applications. The HYDROMINE™ HMP\_11A PN16 Resilient Seal Gate valve are manufactured with a bolted bonnet, flanged, face to face dimensions to SANS 665 / BS 5163 pattern, rising spindle and it's handwheel operated. The benefit of using rising spindle gate valve is that it can immediately be seen if the valve is in an open, closed or partly open position.

### Low Operating Torque:

The HYDROMINE™ HMP\_11A PN16 Resilient Seal Gate Valve is quite easy opening and closing under pressure with a low operating torque.

### Low Maintenance Requirement:

The HYDROMINE™ HMP\_11A PN16 Resilient Seal Gate valve does not have a lot of parts and does not require a lot maintenance.

### Materials Of Construction:

No	Part Name	Specification
1	Handwheel	Cast iron FBE Coated
2	Bush nut	Brass
3	Spindle	410 S/Steel
4	Gland seal	NBR O-Ring
5	Cap Screws	Grade 12.9
6	Spindle nut	Brass
7	Body	SG Iron Fusion Bonded Epoxy coated or NBR Encapsulated on request
8	Gate	SG Iron NBR or EPDM Encapsulated
9	Handwheel nut	SG Iron
10	Drive bush	DZR
11	Bonnet / Yoke	SG Iron Fusion Bonded Epoxy coated
12	Cover Gland	SG Iron
13	O-Ring	Nitrile (Buna)
14	Bonnet O-Ring	Nitrile (Buna)

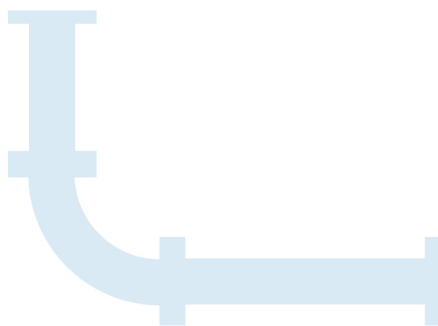
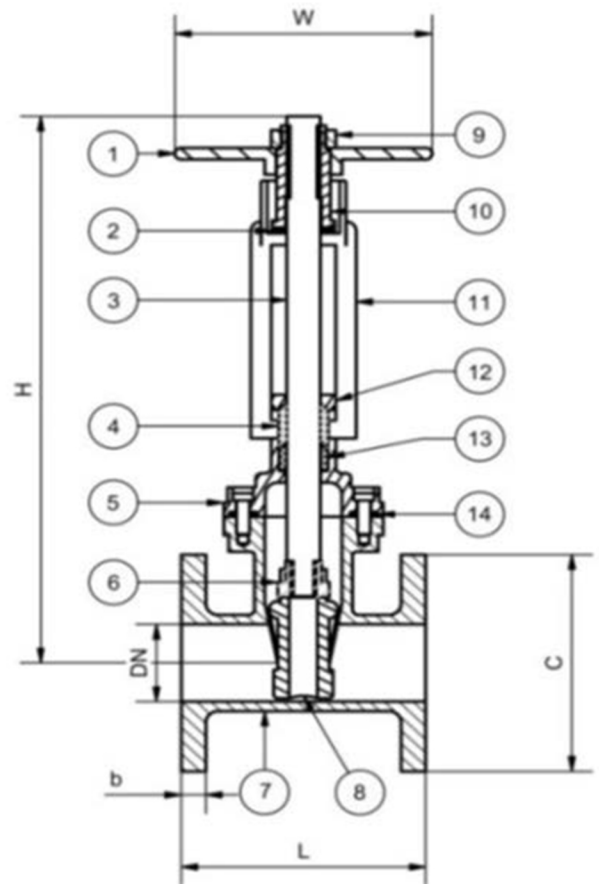



## HYDROMINE™ HMP\_11A SANS 665 / BS 5163 PN16 Resilient Seal Gate Valves

### Dimensions:

Valve Size		Face to face (L)		Centre to top of spindle in closed position (H)		Handwheel Ø (W)		Flange Ø (C)		Flange thickness (b)		Mass	
(DN)	(inch)	(mm)	(inch)	(mm)	(inch)	(mm)	(inch)	(mm)	(inch)	(mm)	(inch)	(kg)	(lbs)
50	2"	178	7,0	280	11,0	180	7,1	165	6,5	20	0,79	14	30,9
65	2 1/2"	190	7,5	320	12,6	180	7,1	185	7,3	20	0,79	14	30,9
80	3"	203	8,0	350	13,8	200	7,9	200	7,9	20	0,79	21	46,3
100	4"	229	9,0	405	15,9	250	9,8	220	8,7	22	0,87	24	52,9
125	5"	254	10,0	440	17,3	300	11,8	250	9,8	24	0,94	36	79,4
150	6"	267	10,5	490	19,3	300	11,8	285	11,2	24	0,94	42	92,6
200	8"	292	11,5	540	21,3	350	13,8	340	13,4	26	1,02	71	156,5
250	10"	330	13,0	720	28,3	400	15,7	405	15,9	30	1,18	101	222,7
300	12"	356	14,0	860	33,9	540	21,3	460	18,1	32	1,26	139	306,4
350	14"	381	15,0	975	38,4	600	23,6	520	20,5	34	1,34	201	443,1
400	16"	406	16,0	1140	44,9	600	23,6	580	22,8	36	1,42	247	544,5
450	18"	432	17,0	1300	51,2	600	23,6	640	25,2	36	1,42	360	793,7
500	20"	457	18,0	1445	56,9	600	23,6	715	28,1	36	1,42	690	1521,2
600	24"	508	20,0	1235	48,6	600	23,6	840	33,1	40	1,57	830	1829,8

### Design & Manufacturing Standards:

The HYDROMINE™ HMP\_11A PN16 Resilient Seal Gate Valve are designed in accordance with various international standards as set out below:

SANS 665  
 BS 5163

Flange drilling can be drilled to the following standards:

ANSI B16.1 Class 125	BS 4504 / D.I.N. T6
ANSI B16.5 Class 150	BS 4504 / D.I.N. T10
SANS 1123 T600	BS 4504 / D.I.N. T16
SANS 1123 T1000	BS 10 / AS2129
SANS 1123 T1600	Table D BS 10 / AS2129
EN1092 PN10 and PN16	Table E JIS B2239 5K and 10K

